



flowpress[®]

Eco Single & Twin Pump
Pressurisation Units

OPERATION AND MAINTENANCE MANUAL

First Publication Date: 01/09/2020

Revision:

Revision Date:

Description	7
Equipment Overview	8
Principal of Operation	8
Installation	9
Pipe Connections	9
Typical Installation Diagram	9
ECO Clearance and Connection Requirements	10
Electrical Power Supply	11
Micro Controller	12
Fault contacts	12
Commissioning	13
Pre-Commissioning Checklist	13
Controller Overview	14
Controller Programming	15
Program List	16
Hydraulic Commissioning	19
1 – Float Valve Setting	19
2 – Bleeding Pumps	19
Forcing Pumps to Run	20
3 – Initial Start-up	21
4 – Testing	21
Operation	22
Fault Codes	22
Shutdown procedure	22
Start-up Procedure	23
Maintenance	23
Visual Inspection	23
Interrogate Controller	23
Test Unit Operation	23
Check Float Valve Operation	24
Check Float Switch Operation	24
Check Break Tank Water Condition	24
Check Strainer (FSDA units only)	24
Check Expansion Vessel Pre-Charge	24
Wiring diagram	25
Wiring location list	26
Spare Parts	27
ECO Models	28
Troubleshooting	29
Warranty Details	31
Warranty - What Is Not Covered?	31
Site Visit	31
Commissioning	31
Liability	31
Contact Details	31
Service Record	31

General Information

These instructions are to assist in the installation of the flowpress ECO Pressurisation Units please follow them carefully.

If, having read this Operation & Maintenance Manual, there is any doubt about any aspect of the installation please don't hesitate to contact our technical team.

Definitions of Safety Warnings and Precautions



WARNING!

Indicates a potentially hazardous situation which, if not avoided, can result in serious injury or death.



CAUTION!

Indicates a potentially hazardous situation which, if not avoided. Can result in minor to moderate injury, or serious damage to the product.

Safety

Information

It is essential that correct and safe working practices are adhered to at all times when installing, operating and/or maintaining any piece of equipment. Always consult safety data sheets, operating and maintenance manuals, Health & Safety legislation and recommendations and specific requirements of any equipment manufacturer, site controller, building manager or any other persons or organisation relating to the procurement, installation, operation and/or maintenance of any piece of equipment associated or in conjunction with any product provided by **flowtech** Water Solutions.

This document is intended for ALL installers, operators, users and persons carrying out maintenance of this equipment and must be kept with the equipment, for the life of the equipment and made available to all persons at all times. Prior to carrying out any work associated with the set it is essential that the following sheets are read, fully understood and adhered to at all times.

Equipment must only be installed, operated, used, and/or maintained by a competent person. A competent person is someone who is technically competent and familiar with all safety practices and all of the hazards involved.

Any damage caused to any equipment by misapplication, mishandling or misuse could lead to risk of Electrocutation, Burns, Fire, Flooding, death or injury to people and/or damage to property dependent upon the circumstances involved. **flowtech** Water Solutions accepts no responsibility or liability for any damage, losses, injury, fatalities or consequences of any kind due to misapplication, mishandling or misuse of any equipment, or as a result of failure to comply with this manual.

Failure to install, operate, use or maintain the equipment in accordance with the information contained within this document could cause damage to the equipment and any other equipment subsequently connected to it, invalidating any warranties provided by **flowtech** Water Solutions to the buyer.

SAFETY WARNINGS &

PRECAUTIONS

These instructions should be read and clearly understood before working on the system. Please read this manual carefully and all of the warning signs attached before installing or operating the equipment keep this manual handy for your reference. This equipment should be installed, adjusted and serviced by trained and qualified personnel. Failure to observe this precaution could result in bodily injury.



WARNING! - Install an emergency stop key separately from the isolator. Rotating shafts can be hazardous.



WARNING! - This equipment has a high leakage current and must be permanently fixed to earth.



WARNING! - Do not attach or remove wiring or connectors when the power is applied. Do not check signals during operation. When the power is turned on and the running command is on, the motor will start rotating. The stop key is only effective when the function is set. If there is a power failure and an operation instruction is given the unit may start automatically when the power is reinstated.



WARNING! - Make sure that the input voltage is correct. Be sure to install the unit in a room that is not exposed to direct sunlight and is well ventilated.

Avoid environments which have a high ambient temperature, high humidity or excessive condensation. Avoid dust. Corrosive gas, explosive gas, inflammable gas, grinding-fluid mist and salt damage, etc.



WARNING! - Do not connect the power source to any terminals except power connectors.



WARNING! - Motor control equipment and electronic controllers are connected to hazardous line voltages. When servicing drives and electronic controllers, you may be exposed to components at or above the line potential. Extreme care should be taken to protect against shock. Dangerous voltage may exist after the power light is off.

Wait more than 5 minutes after turning off the power supply before performing maintenance or inspection. Hazard of electric shock. Disconnect incoming power before working on this unit.



WARNING! - The inverter should be protected separately against ground fault.

Observe the regional regulations for electrical installation!



CAUTION! - It is strongly recommended that all electrical equipment conforms to National Electrical Codes and local regulations. Only qualified personnel should perform installation, alignment and maintenance. The manufacturer reserves the right to alter the technical data in order to make improvements or update information.



CAUTION! - Failure to observe these rules will render the guarantee invalid. The same applies to repair jobs and/or replacement. Your legal rights are not affected.



CAUTION! - The manufacturer declines all responsibility in the event of damage or injury caused as a result of tampering with the equipment.



CAUTION! - Do not switch on/off power supply to run/stop the motor/system! Start the unit only by using run button or external run command.



We strongly recommend that commissioning and service work is carried out by the manufacturer's personnel or appointed agents ~ please contact our technical sales department for information on our commissioning and service contract packages.

CUSTOMER / CONTRACTOR

RESPONSIBILITIES

It is the responsibility of the customer and/or the contractor:

- To ensure that anyone working on the equipment is wearing all necessary protective gear and/or clothing.
- Is aware of appropriate health & safety warnings.
- Has read the information in this section of the manual.

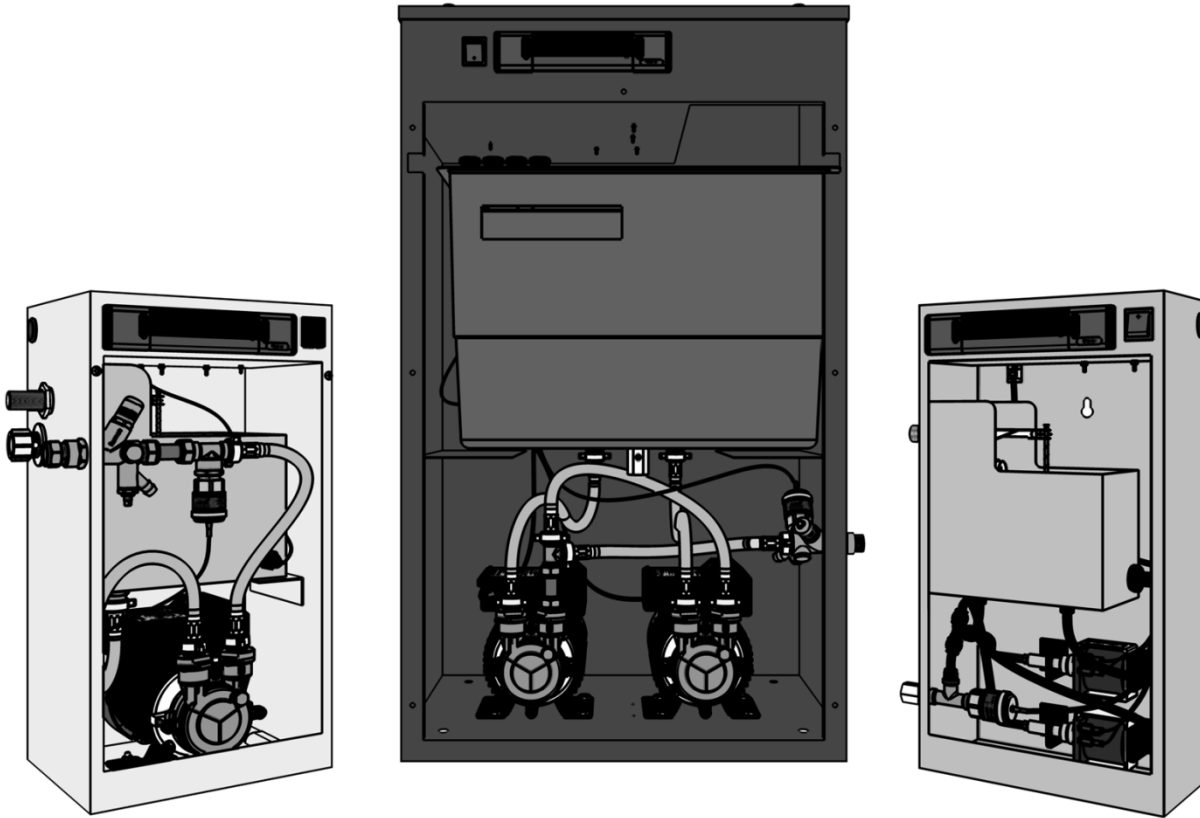

Note - It is highly recommended to have this equipment commissioned by a Flowtech approved engineer. Any damage or loss incurred through incorrect commissioning by an unapproved engineer will not be covered by the warranty.

If you wish for Flowtech to arrange this please contact us.

Please see the warranty section for details.

Remember to fill in details for future use for re-commission unit.

Remember – When installing a expansion vessel with the pressurisation unit make sure the cold pressure is the same in order for the system to work effectively.

Flowpress WMDA 1-1 and Flowpress WMDA 1-2 - Under no circumstances must be used to fill a system of any size.

Description

This Operation and Maintenance Manual contains all the necessary information to install, commission, operate and maintain Flowpress pressurisation equipment.

It is recommended to read all parts of this manual before undertaking any work on the equipment.

Equipment Overview

The function of this pressurisation unit is to provide a means of automated water top-up to sealed heating and cooling systems. The equipment is designed to provide periodic water top-up to compensate for minor losses in system pressure (e.g. slow leaks, air venting, etc.).

This equipment is not designed to cope with sudden losses of system pressure (e.g. manual draining) or major water losses (e.g. large leaks). The equipment is also not intended to be used for water boosting applications.

Principal of Operation

The following schematic shows the internal arrangement of a pressurisation unit:

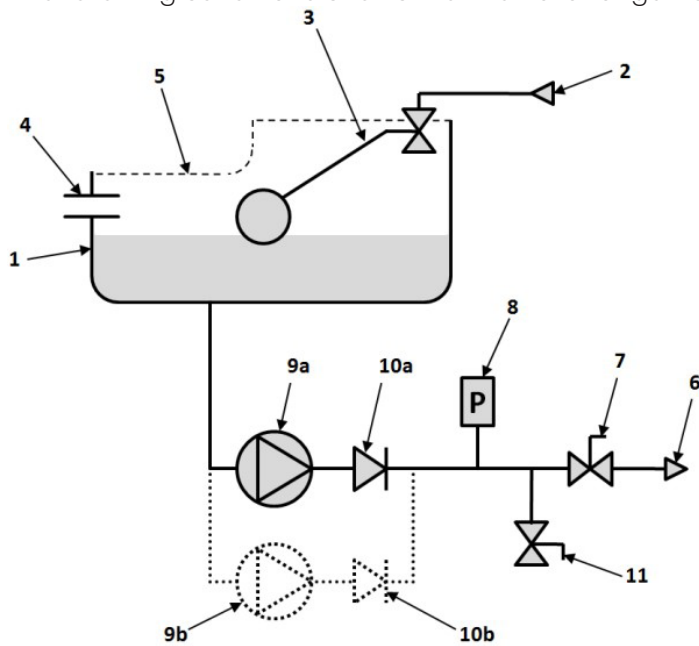

The pressurisation unit is fitted with a break tank (1) which is filled from the mains water supply (2) via a float operated valve (3). The break tank is fitted with an overflow (4) in case the break tank overfills, and a weir overflow (5) in case the primary overflow fails.

The pressurisation unit is connected into the heating system (6) via an isolation valve (7). The pressure sensor (8) monitors the system pressure.

If the pressure sensor detects a drop in pressure, the pump (9a) will pump water from the break tank into the system. Once the required pressure has been reached, the pump will stop.

On twin pump models, a second pump (9b) is provided. The two pumps will run in a duty/standby configuration (i.e. the active pump will alternate with each pump start).

The pump(s) are fitted with non-return valves (10a, 10b) to prevent backflow.

A drain valve (11) is provided for draining down the unit and for commissioning purposes.

Installation

This pressurisation unit is not designed to be installed in an outdoor environment. The unit must be installed in a frost free environment, away from precipitation and water sprays/jets. If there is a risk of flooding, the unit must be installed on a raised plinth.

Please refer to the appropriate datasheet for the maximum working pressure and temperature of the pressurisation unit. The conditions at the point of connection to the system must not exceed these values.

Pipe Connections

To avoid damaging the float valve, the mains water supply pipe must be flushed before connection to the pressurisation unit.

All pipe connections must be made with appropriate jointing compound/PTFE tape. If PTFE tape is used, care must be taken to ensure that the tape does not obstruct the orifice of the fitting.

Non-return valves, pressure reducing valves and RPZ valves must not be installed between the pressurisation unit and the heating/cooling system. These devices will prevent the pressure sensor from reading the system pressure.

The pressurisation unit and expansion vessel should be connected to the system at the same point, to provide a neutral pressure reading. This point of connection should be in the system return, on the suction side of the circulation pump.

Typical Installation Diagram

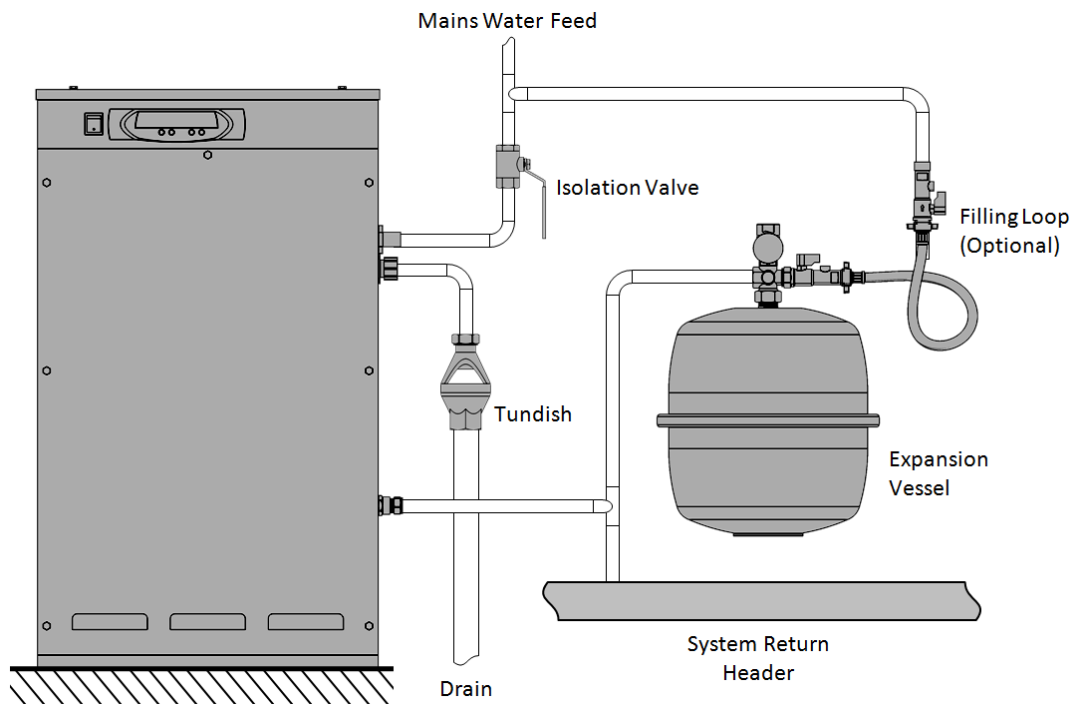

ECO Clearance and Connection Requirements

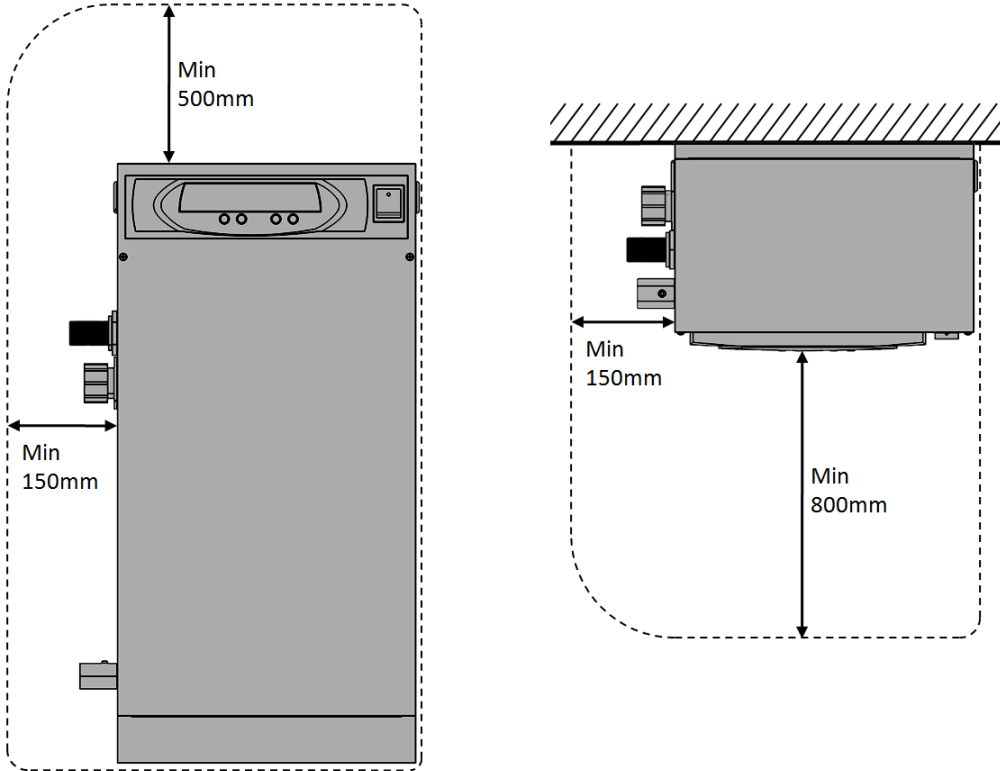

Connection	Size	Notes
Mains Water Feed	½" BSP M	An isolation valve must be installed on the mains water feed for servicing.
Break Tank Overflow	22mm	Guidance on drainage requirements should be obtained from the local water authority.
System Connection	¼" BSP F	The pressurisation unit and expansion vessel should be connected to the system at the same point. The point of connection should be in the system return, on the suction side of the circulation pump. Non-return valves, pressure reducing valves and RPZ valves must not be used.

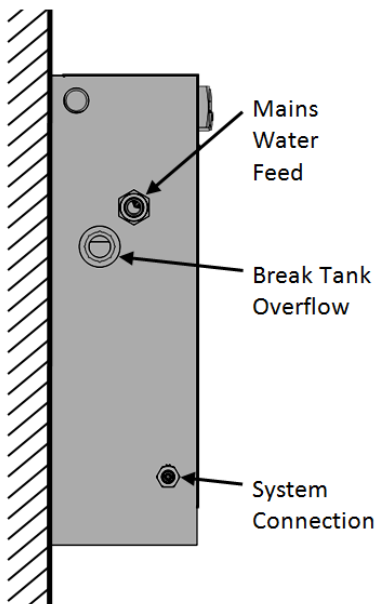

Electrical Power Supply

This equipment must be electrically isolated before removing the covers. Cables connected to the volt free contacts may be supplied from another source and may remain live after the unit is isolated. These must be isolated elsewhere.

All electrical connections must be carried out by a suitably qualified and competent person. The mains power supply to the pressurisation unit must be connected into the fused terminal block as shown below:

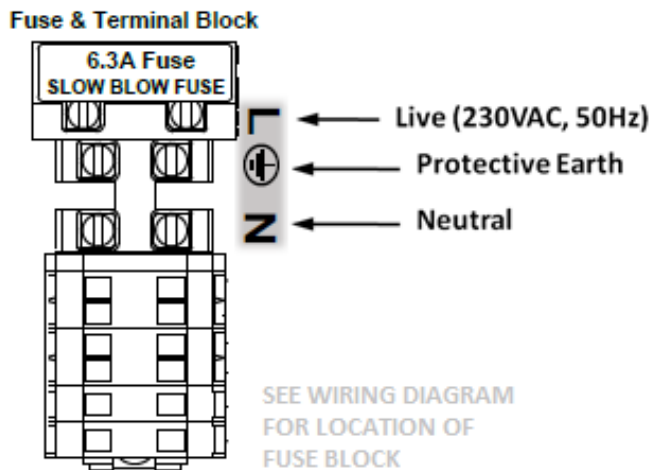

On some larger models, the fused terminal block is replaced by a fused spur. If this is the case, the power supply must be connected into the fused spur, as shown below:

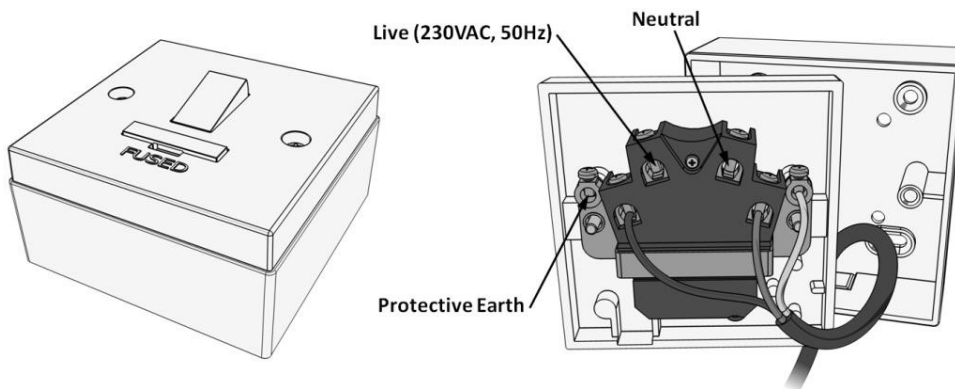

It is recommended to supply power to the pressurisation unit via a lockable isolator. This should be installed within 2m of the equipment.

This equipment can be damaged by the high voltages produced by electrical installation testing equipment. When performing electrical installation tests, the equipment must be isolated from the supply.

Micro Controller

Fault contacts

There are 6 volt free fault contacts which can be used for connection to a BMS system, or as a boiler interlock. These are terminals 1-12, located on the digital controller:

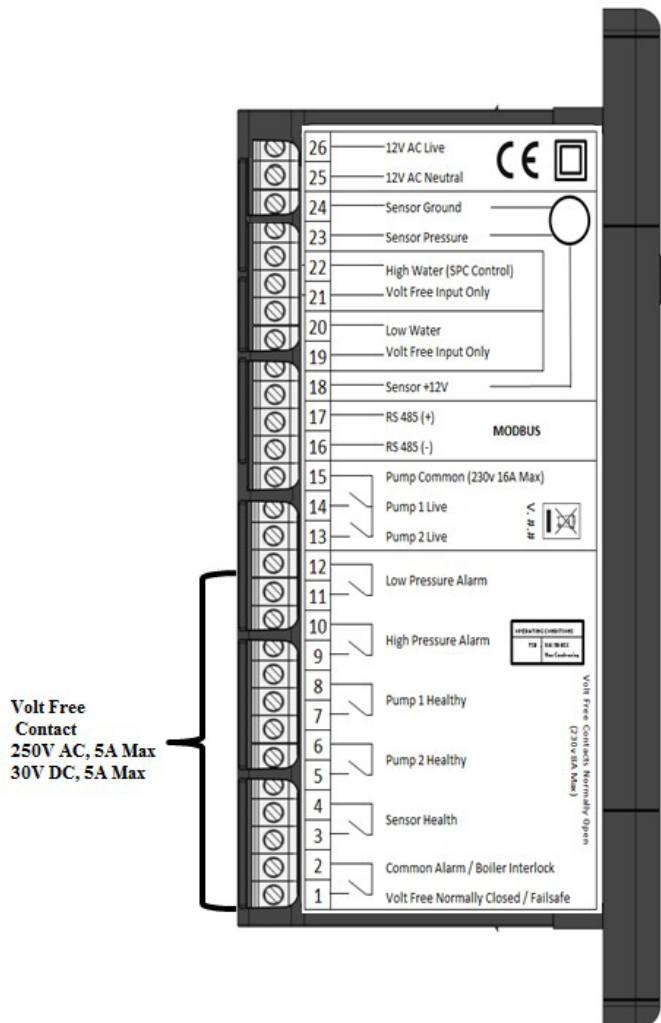

With the exception of the Common Alarm, it is possible to convert all other fault contacts to normally closed. For further information please refer to the commissioning section of this manual.

The other volt free contacts you can connect to the BMS and when the alarm is triggered this is shown on the Pressurisation unit and the BMS. So you can indication if something is in fault with the unit.

Commissioning

It is highly recommended to have this equipment commissioned by a Flowtech approved engineer. Any damage or loss incurred through incorrect commissioning by an unapproved engineer will not be covered by the warranty.

Pre-Commissioning Checklist

The following conditions must be met before starting the commissioning process. Failure to meet these conditions may result in injury or damage to the equipment, system and property.

Equipment is sited in a frost free area, away from precipitation and water sprays/jets

All necessary pipe/electrical connections have been made to a satisfactory standard

The temperature and pressure at the point of connection are within the operating limits of the pressurisation unit.

The heating/cooling system is fitted with a safety valve and expansion vessel

The following conditions must be met for the pressurisation unit and heating/cooling system to function correctly. If these conditions have not been met, it is not advisable to proceed with the commissioning process.

The system connection has been made into the system return header/pump suction

There are no non-return valves, pressure reducing valves or RPZ valves installed between the pressurisation unit and the heating/cooling system

The expansion vessel is pre-charged to the correct pressure (equal to fill pressure)

It is advisable to fill the heating/cooling system prior to commissioning. If this is not possible, the pressurisation unit can be used to fill the system after commissioning. Depending on the size of the system, this may take a considerable amount of time.

The heating/cooling system is filled and pressurised to the required cold fill pressure, with the water at ambient temperature (approximately).

Controller Overview

The following image shows the front of the pressurisation unit digital controller. 4 buttons are provided for programming, and an LED display which shows scrolling messages.



When the controller is first powered up, it will display the controller version number. This manual relates to controller version >8.0. If the controller is of a different version, there may be differences in the menu items available.

When in normal operation, the controller will display the current system pressure. If a fault occurs, the controller will display a fault code and produce an audible alarm.

In normal operation, the functions of the buttons are as follows:

Button	Function	
	Press	Hold
SET	-	Show Current System Pressure
MUTE	Mute Audible Alarm	Reset Unit
+	-	Enter Programming Menu
-	-	Enter Programming Menu

Controller Programming

Do not alter any settings without first understanding the implications of doing so. Incorrect settings may cause damage to the equipment, system or property.

To enter the programming menu, hold the (+) button until “enter code” appears on the screen, followed by “0000” with a flashing cursor after the first digit.

To gain access to the programming menu, one of the following codes must be entered:

Customer Code	Standard set of options	2601
---------------	-------------------------	-------------

To enter the code, change the first digit with the (+) and (-) buttons, then press (SET) to move onto the next digit. Repeat for all digits, then once the correct code is shown on the display, press (SET) to enter the programming menu.

Once a correct code has been entered, the first option [COLD FILL] will appear on the screen.

Once in the menu, the value of the current menu item can be changed using the (+) and (-) buttons. Once the current value has been set, pressing the (SET) button will move on to the next option.

It is not possible to navigate backwards through the menu. To return to a previous setting in the menu, press the (SET) button repeatedly to scroll through to the end of the menu, and then re-enter the appropriate code.

If the controller loses power while in the programming menu, all changes made will be erased. To confirm all changes, the end of the menu must be reached, and the “SAVING...” message must be displayed.

Program List

The table below gives details of all menu items, in the order that they will appear:

#	Menu Item	Function	Default Value
1	COLD FILL	The required fill pressure, i.e. pump 'cut-out' pressure. The recommended setting is 0.3 BAR above the static pressure of the system (0.1 Bar per meter of static height). For example, a 14m high installation will have a static pressure of 1.4 Bar, making the recommended cold fill pressure 1.7 Bar. It is not possible to enter a value higher than the current [HIGH SET] or lower than the current [LOW SET] values.	1.0 Bar
2	HIGH SET	The high pressure alarm setting. If the pressure in the system reaches this value, the <HIGH PRESSURE> alarm and common alarm will be activated. The recommended setting is 10% below the safety valve rating. For example, if the safety valve rating is 3 Bar, the recommended setting is 2.7Bar. It is not possible to enter a value lower than the current [COLD FILL] value.	2.7 Bar
3	LOW SET	The low pressure alarm setting. If the pressure in the system falls below this value, the <LOW PRESSURE> alarm and common alarm will be activated, and the pressurisation pumps will not run. The recommended setting is 0.5 Bar below the [COLD FILL] pressure. It is not possible to enter a value higher than the current [COLD FILL] value.	0.5 Bar
4	DIFFERENTIAL	The differential between the 'cut-in' and 'cut-out' pressures of the pressurisation pumps. The cut-in pressure will be equal to the [COLD FILL] pressure, minus the differential pressure. For example, if the [COLD FILL] pressure is set to 1.5 bar, and the differential set to 0.2 Bar, the pump 'cut-in' pressure will be 1.3 Bar (1.5 – 0.2 = 1.3)	0.2 Bar
5	FLOOD LIMIT	The maximum continuous run time for each of the pressurisation pumps. If a pump runs continuously for longer than this period, the pump will stop and a <FLOOD LIMIT> alarm will be activated. This is to prevent the unit from pumping large amounts of water in the event of a large leak/burst pipe. For very large systems, this may need to be increased. The value can be changed in increments of 10 minutes, to a maximum of 990.	10 MINS
6	PUMP 1 COUNT	The cumulative number of pump starts for pump 1. This is a cumulative counter, the value of which cannot be modified. If using the engineer's code, the counter can be reset to zero by holding the (MUTE) button.	-
7	PUMP 1 HOURS	The cumulative run time in hours for pump 1. This is a cumulative timer, the value of which cannot be modified. If using the engineer's code, the counter can be reset to zero by holding the (MUTE) button.	-
8	PUMP 2 COUNT	The cumulative number of pump starts for pump 2. This is a cumulative counter, the value of which cannot be modified. If using the engineer's code, the counter can be reset to zero by holding the (MUTE) button.	-
9	PUMP 2 HOURS	The cumulative run time in hours for pump 2. This is a cumulative timer, the value of which cannot be modified. If using the engineer's code, the counter can be reset to zero by holding the (MUTE) button.	-
10	ALARM COUNT	The cumulative number of all alarm incidents. This is a cumulative counter, the value of which cannot be modified. If using the engineer's code, the counter can be reset to zero by holding the (MUTE) button.	-

11	POWER INTERRUPTED	The cumulative number of power interruptions (i.e. controller turned off/power cut). This is a cumulative counter, the value of which cannot be modified. If using the engineer's code, the counter can be reset to zero by holding the (MUTE) button.	-
12	PULSE	When enabled, if a pump has been inactive for 60 days, it will start and run for 2 seconds. This is to prevent the pumps from seizing.	YES
13	EXCESSIVE START	When enabled, if there are more than 3 individual pump runs within an 8 hour period, the unit will register an <EXCESSIVE DEMAND> alarm. Enabling this option may cause false alarms on some systems.	NO
14	SERVICE	When enabled, a service reminder will be displayed after 12 months from when the option was enabled. To reset the service reminder, set the value to 'NO' and exit the menu. Then, re-enter the menu and set the value to 'YES' again.	NO
15	FILL SYSTEM	When enabled, the <LOW PRESSURE> and <FLOOD LIMIT> alarms will be disabled, and pump 1 will run continuously for up to 24 hours until the cold fill pressure has been reached. Once the cold fill pressure has been reached, this option will automatically be deactivated, and the low pressure alarm and flood limit will be reactivated. This function is used to fill a system that is empty or at low pressure. Care must be taken using this option as the flood limit alarm is disabled, increasing the risk of flooding. This option cannot be enabled on Mini pressurisation units.	NO

If using the customer code, the menu will end at this point. After pressing (SET) once more, the controller will display "SAVING..." and return to normal operating mode. If using the engineer's code, additional menu items will be displayed.

The following settings are all pre-programmed in the factory and should not need to be modified on site. If these settings appear to have been reset, the most likely cause is a power spike. If this problem persists, a power filter may be required.

The following settings are for experienced engineers only. Incorrect configuration of these settings can cause the equipment not to function correctly, and may cause damage to the equipment, system or property.

#	Menu Item	Function	Default Value
16	PUMPS NUMBER	The number of pumps installed in the pressurisation unit. This can be set to either 1 or 2.	2
17	PUMP TYPE	The type of pump installed in the pressurisation unit. There are two options, which are as follows: 0 – Centrifugal Pump 1 – Piston Pump	0
18	PUMP SENSE	Disabling this option will stop the controller from monitoring the pumps and generating <PUMP FAIL> faults. It is not recommended to disable this option.	YES
19	SENSOR TYPE	The type of pressure sensor installed in the unit. There are two options which are as follows: 1 – 1-6V Output, 0-10 Bar Range 2 – 1-6V Output, 0-16 Bar Range	1
20	SPC CONTROLLER	Not required on standard Pressurisation unit	NO

21	ADDITIVE	Not required on standard Pressurisation unit	NO
22	ID NUMBER	A user configurable identification number. This option does not serve any functional purpose.	01
23	RELAY INVERSION	When enabled, all normally open fault contacts (i.e. all except the common alarm) are converted to normally closed.	NO
24	OVERRUN	Allows the pump to continue running for a set period of time after the required pressure has been reached. This will prevent the pumps from 'hunting'. The value can be set from 0 – 10 seconds.	5
25	PRESSURE ALARM AUTO RESET	When enabled, the <HIGH PRESSURE> and <LOW PRESSURE> alarms will be cleared automatically if and when the pressure returns to normal. If disabled, the alarms must be manually reset.	YES
26	BOOST	When enabled, the controller will allowing the pumps to run even if the system pressure is zero.	NO
27	CASCADE	Allows the pumps to operate in duty/assist mode. After either pump starts, the other pump will start after a set period of time. This option can be set to OFF, or 5 – 30 seconds.	OFF
28	SOLENOID CONTROLLER	When enabled, the "high water" input is used to trigger a top up solenoid valve connected to the "sensor healthy" volt free contact. This option should only be enabled on units which utilize a solenoid valve as the means of top-up.	NO

Hydraulic Commissioning

1 – Float Valve Setting

Ensure that the break tank float valve is set to its lowest position:

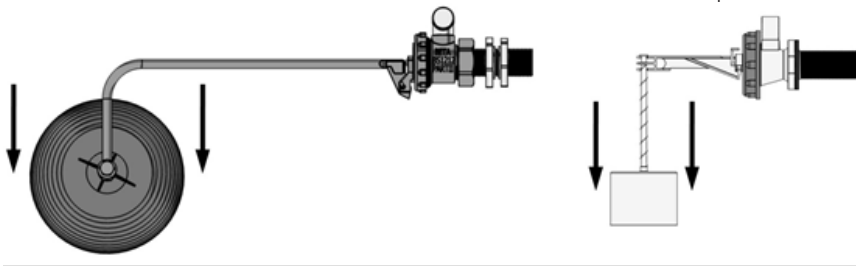

If a drain valve is fitted to the break tank, ensure that it is closed. Then, turn on the mains water supply and allow the break tank to fill.

When the float valve operates for the first time, it may not close immediately, causing the break tank to overflow. Once the internals of the valve have been fully wetted this should not occur again.

2 – Bleeding Pumps

This step is only necessary for FSDA and WMDA units. For WMDA units, move on to the next step.

Make sure that the internal isolation valve within the pressurisation unit is closed by following the steps below. Failure to do this may cause injury or damage to the equipment, system or property.

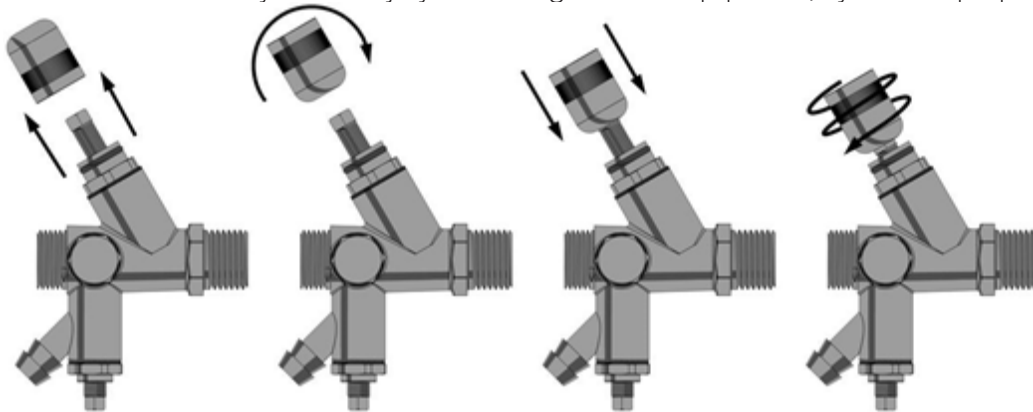

Un-screw cap

turn cap

push cap on socket

Twist cap

Attach a length of hose to the hose tail on the drain valve and put the other end to drain. Then, using the cap off the isolation valve, open the drain valve:

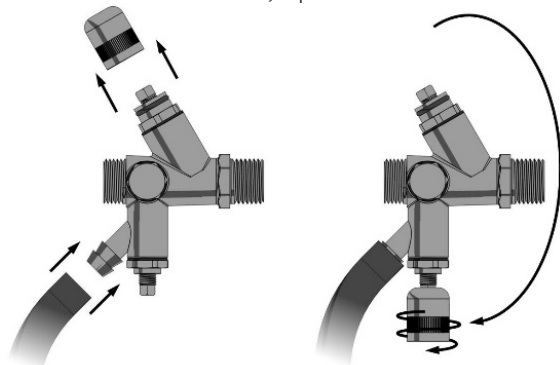

Locate the bleed screw on the pump. The following diagrams show examples of typical bleed screw

locations for most pumps:

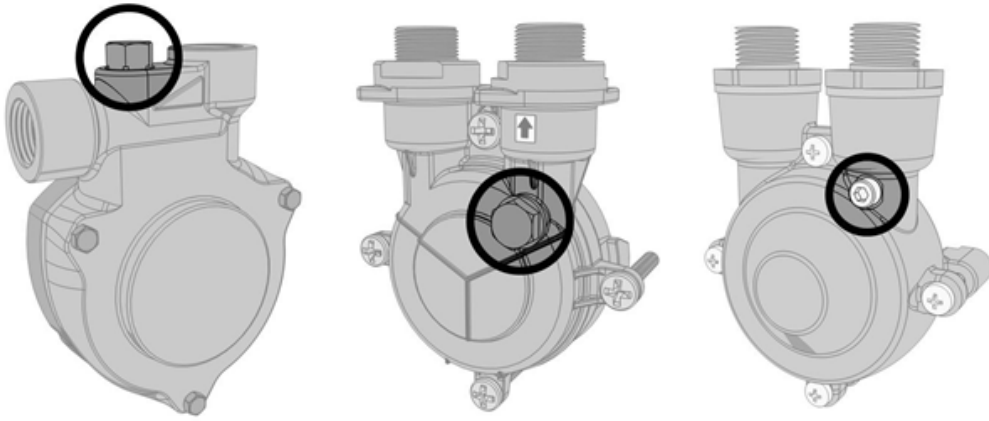

Do not use excessive force when tightening the bleed screw as this may damage the pump casing.

If the pump has a plastic bleed screw like the one shown below, do not use excessive force or attempt to use any tools to turn it as this may damage the pump casing.

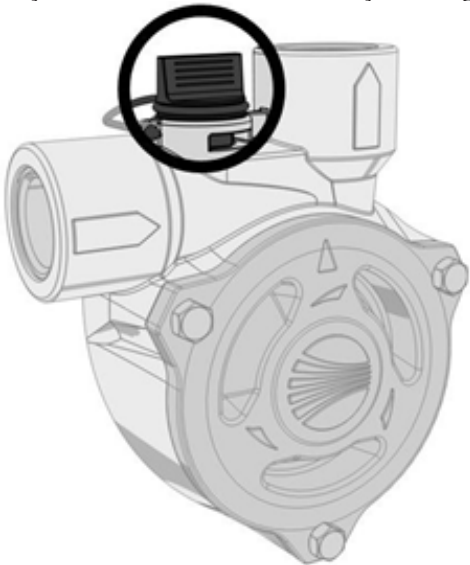

Forcing Pumps to Run

Turn on the power supply to the digital controller and wait for the system pressure to appear on the display. Then, enter the code 2601 and go to the first setting in the menu, cold fill. While at this point in the menu, holding down the (MUTE) button will force pump 1 to run, and holding down the (SET) button will force pump 2 to run.

If the controller is older than V6.1 then there is no way to force pump 2 to run via the controller. To force the second pump to run, the unit must be isolated and the live wires in terminals 13 and 14 must be swapped over. The second pump then becomes “pump 1” and can be forced to run via the controller.

To bleed the pumps, the pumps must be started. Then while the pump is running, the bleed screw must be opened until all the air has been removed and only water is being discharged. The bleed screw can then be closed.

Failure to bleed the pumps may result in damage to the equipment, system and property.

After bleeding the pumps, close the drain valve and remove the hose from the hose tail.

3 – Initial Start-up

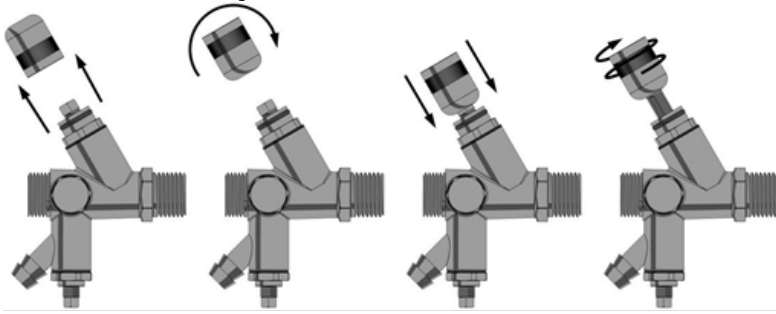

Open the internal isolation valve within the pressurisation unit by following the steps below:

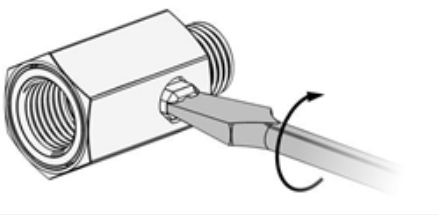

Once the isolation valve is open, the pressure sensor will be able to read the system pressure.

Turn on the power supply to the pressurisation unit. Depending on the current system pressure, the unit will respond in one of the following ways:

If the system pressure is below the low pressure alarm setting, the controller will display a “LOW PRESSURE” fault and the pumps will not run. To clear this fault, either increase the system pressure using a filling loop, or enable the system fill option on the pressurisation unit.

If the system pressure is above the high pressure alarm setting, the controller will display a “HIGH PRESSURE” fault. To clear this fault, use a suitable drain point to remove water from the system until the system pressure equals the cold fill pressure.

If the system pressure is above the low pressure alarm setting, but below the cold fill setting (by an amount equal to the differential setting), the pumps will start. Once the system pressure has reached the cold fill pressure, the pump will stop.

Once the required system pressure has been reached, the controller will display the current system pressure. The unit is now in normal operation.

4 – Testing

To test the operation of the pressurisation unit while connected to the system, the system pressure must be lowered slowly to simulate a minor leak.

This can be achieved by using a drain point on the system, the drain point on the pressurisation unit, or by manually opening the safety relief valve.

Care must be taken not to let the pressure drop too quickly. If the system pressure falls below the low pressure set point, a low pressure fault will be displayed and the pumps will not run. The pressurisation unit is not designed to cope with a sudden loss of system pressure, which would be symptomatic of a catastrophic failure such as a burst pipe.

Once the system pressure has fallen below the cold fill setting (by an amount equal to the differential setting), the pump should start refilling the system. The pump will continue to run until the cold fill pressure has been reached.

This test demonstrates the primary function of the pressurisation unit. This test may be repeated at any time to confirm the operation of the pressurisation unit.

Operation

Once commissioned, the pressurisation unit should operate without any user intervention. Under normal operating conditions, the display will show the current system pressure in Bar.

While the unit is filling, the display will show <PUMP 1 RUN> or <PUMP 2 RUN> depending on which pump is currently running.

If the unit identifies a fault, the display will show the relevant fault code.

If the pressurisation unit is showing a fault code on the display, holding down the [SET] button will cause the current system pressure to be temporarily shown on the display.

Fault Codes

The following table gives the meanings of all fault codes used on the digital controller:

Fault Code	Description	Auto/Manual Reset
LOW PRESSURE	The system pressure is below the [LOW PRESSURE] set point.	User Defined
HIGH PRESSURE	The system pressure is above the [HIGH PRESSURE] set point.	User Defined
LOW H2O	The break-tank low level float switch has been activated	Auto Reset
HIGH H2O	The break-tank high level float switch has been activated	Auto Reset
P1 FAIL P2 FAIL	The controller has detected a fault (incorrect current draw) on the respective pump	Manual Reset
P1 FLOOD LIMIT P2 FLOOD LIMIT	The respective pump has run for longer than the [FLOOD LIMIT] period	Manual Reset
ERR. 1	The signal from the pressure sensor is out of range	Manual Reset
EXCESSIVE DEMAND	There have been 4 pump starts within an 8 hour period	Manual Reset
SERVICE	The pressurisation unit is due an annual service	Manual Reset

For practical guidance on diagnosing and rectifying faults, please refer to the Troubleshooting section of this manual.

Shutdown procedure

The pressurisation unit must be shut-down during any of the following scenarios:

- Work is being carried out on the system.
- Work is being carried out on the pressurisation unit
- The heating/cooling system is being flushed

To shut down the pressurisation unit, please follow the steps below:

1. Isolate the electrical power supply to the pressurisation unit
2. Isolate the mains water supply to the pressurisation unit
3. Isolate the pressurisation unit from the system using the internal isolation valve
4. If it is anticipated that the unit will be out of commission for more than 24 hours, it is advisable to drain the water from the break tank.

Start-up Procedure

Attention – This procedure is for restarting the unit after being shutdown (as described above). For initial start-up and commissioning procedures, please refer to the Commissioning section of this manual.

To restart the pressurisation unit, please follow the steps below:

1. Perform a visual inspection of the unit and installation to check for signs of damage
2. Check the break-tank for debris/deposits and remove if necessary
3. Turn on the mains water supply to the pressurisation unit and allow the break tank to fill
4. Open the internal isolation valve
5. Turn on the mains power supply and wait for the controller to start
6. Depending on the conditions in the system, the unit may display one or more fault codes at this point.

Maintenance

Due to variations in operating conditions, and the varying loads placed on pressurisation units, it is not feasible to provide accurate predictions of component lifespan. The most effective method of maintenance is to inspect the pressurisation unit for early signs of component failure and take action accordingly.

The following maintenance procedures should be performed at least once a year:

Visual Inspection

A basic visual inspection will highlight the majority of potential faults on a pressurisation unit. It is recommended to perform a visual inspection annually. However, due to the simplicity of performing these checks, frequent inspections are encouraged.

- Check the digital display for fault codes
- Check for signs of leakage (e.g. water, mineral deposits, corroded components/cabinet)
- Check the break tank overflow for signs of water discharge
- Check flexible hoses for signs of degradation (e.g. cracks)
- Check that the pressure reading on the digital display corresponds to the actual system pressure (read off another gauge)

Interrogate Controller

The digital controller keeps a log of the number of pump starts and total hours run for each pump, as well as the number of alarm activations and power interruptions. It is advisable to take a note of these figures when servicing the unit, as they may be helpful in diagnosing potential issues. Fields are provided in the service log for these figures.

It is advisable to scroll through all the settings (including engineers setting) and check them against the figures on the commissioning report. If there are any discrepancies, check first with on-site staff to see if the changes are deliberate. If not, reconfigure appropriately.

If settings are persistently becoming corrupted, a power filter may be required. Please refer to the Installation section of this manual for more information.

Test Unit Operation

The best way to test the operation of the pressurisation unit is to drain water from the system, allowing the pressure to drop slowly. Once the pressure falls below the pump cut-in pressure ([COLD FILL] – [DIFFERENTIAL]) the pump should start. As soon as the pump starts, close the drain point and allow the system pressure to rise.

Once the [COLD FILL] pressure is reached, the pump should stop.

If the unit is a twin pump model, this test should be repeated until both pumps have run and successfully re-pressurised the system.

Check Float Valve Operation

To test the operation of the break tank float valve, first ensure that the break tank overflow has a suitable path to drain.

Gently push down on the arm of the float valve until it starts to discharge water, then release the float valve arm. Once the arm has been released, the flow of water should stop within a few seconds.

Check Float Switch Operation

To test the operation of the break tank low level float switch, reach into the break tank and gently push the float switch down into the horizontal position.

The digital controller should now display a <LOW H2O> fault.

Release the float switch and observe the display. The fault should clear after a delay of a few seconds.

Check Break Tank Water Condition

Perform a visual check of the water in the break tank. If there is any dirt or debris in the water, or deposits on the sides of the tank, the tank should be drained down and cleaned.

Check Strainer (FSDA units only)

Flowpress FSDA pressurisation units are fitted with a mesh strainer in the connection at the bottom of the break tank.

This should be removed and inspected. Depending on the condition, this part may need to be cleaned or replaced.

Check Expansion Vessel Pre-Charge

Many of the problems experienced with pressurisation equipment can be traced back to the expansion vessel.

The expansion vessel pre-charge pressure must be checked after 2 years and annually thereafter.

To perform this test, the expansion vessel must first be drained of water, then a gauge can be connected to the Schrader valve on the vessel to measure the pre-charge pressure. The pre-charge should be equal to the [COLD FILL] pressure setting.

The pressure can be increased using a foot pump, air compressor or pressurised air/nitrogen cylinder.

If any faults are identified during these checks, please refer to the Troubleshooting section of this manual.

Wiring diagram

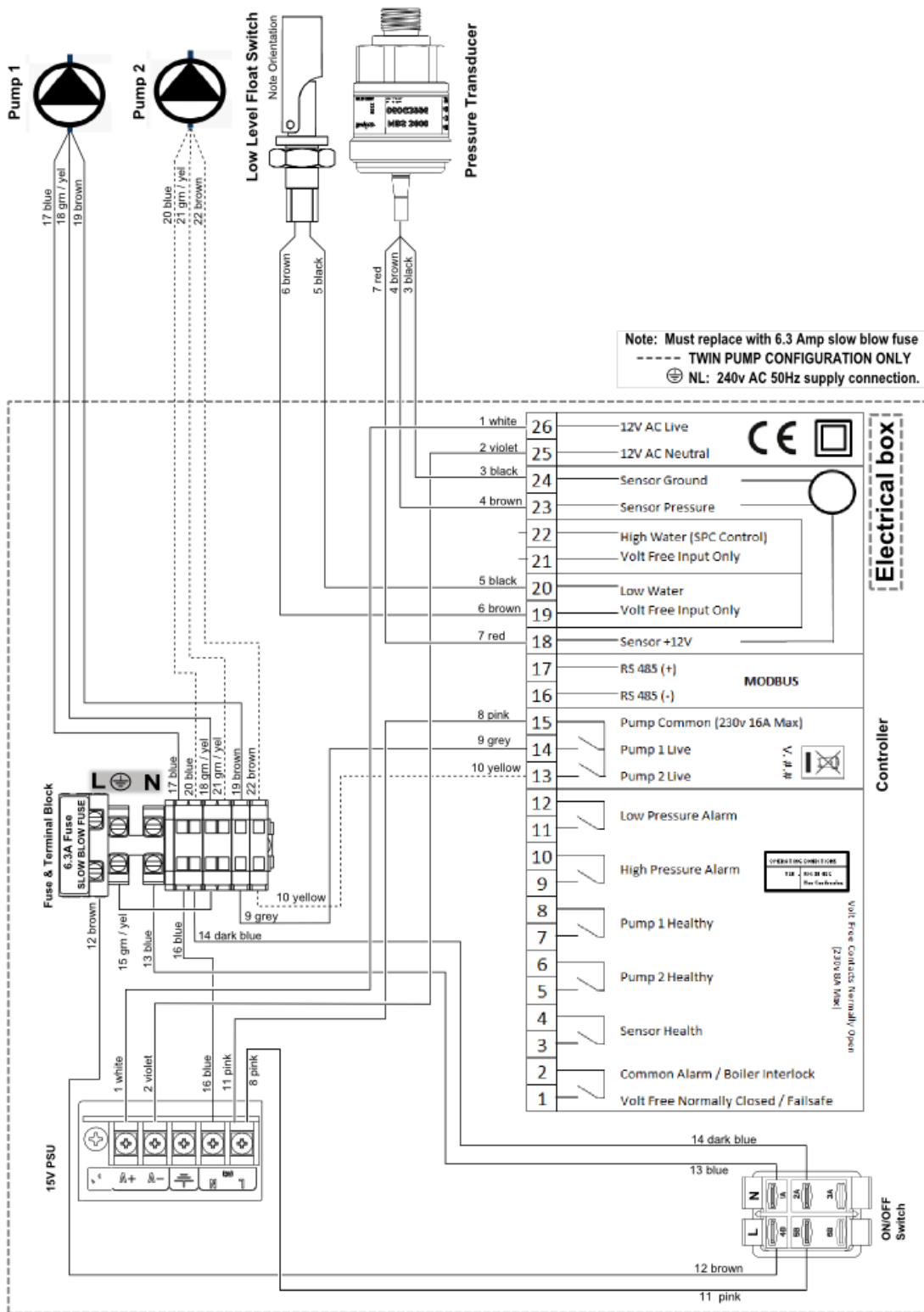

Wiring location list

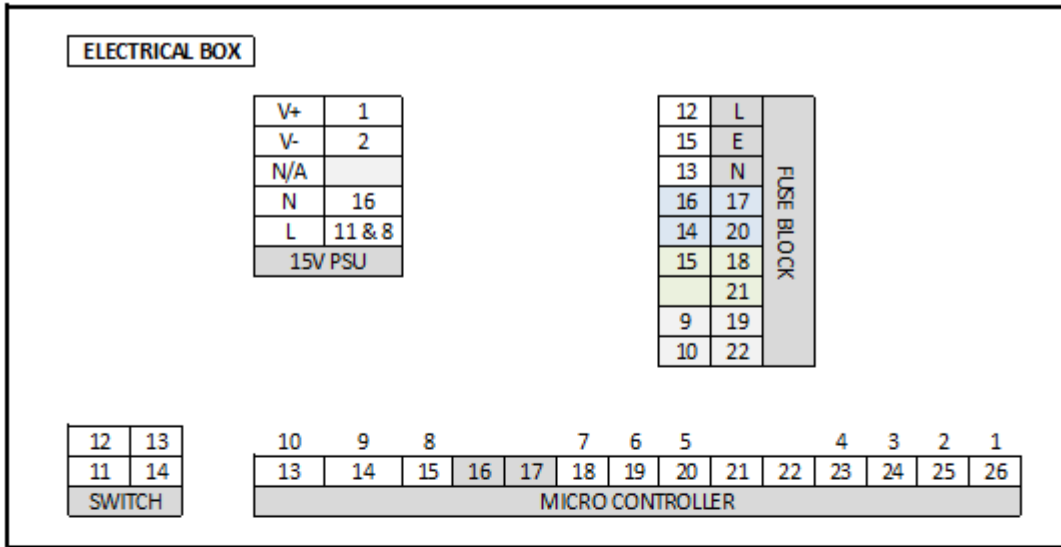

WIRING LOCATION

No	Colour	Connection	→	Connection	
1	White	Controller (26)		15V PSU (V+)	
2	Violet	Controller (25)		15V PSU (V-)	
3	Black	Controller (24)		Transducer	
4	Brown	Controller (23)		Transducer	
5	Black	Controller (20)		Low level Float Switch (Water Tank)	
6	Brown	Controller (19)		Low level Float Switch (Water Tank)	
7	Red	Controller (18)		Transducer	
8	Pink	Controller (15)		15V PSU (L)	
9	Grey	Controller (14)		Fuse terminal	
10	Yellow	Controller (13)		Fuse terminal	TWIN PUMP (ONLY)
11	Pink	Switch (L)		15V PSU (L)	
12	Brown	Switch (L)		Fuse terminal (Grey)	
13	Blue	Switch (N)		Fuse terminal (Grey)	
14	Dark Blue	Switch (N)		Fuse terminal (Blue)	
15	Green/Yellow	Fuse terminal		Fuse terminal (G/Y)	
16	Blue	15V PSU (N)		Fuse terminal (Blue)	
17	Blue	Pump 1		Fuse terminal (Blue)	
18	Green/Yellow	Pump 1		Fuse terminal (G/Y)	
19	Brown	Pump 1		Fuse terminal (Grey)	
20	Blue	Pump 2		Fuse terminal (Blue)	TWIN PUMP (ONLY)
21	Green/Yellow	Pump 2		Fuse terminal (G/Y)	TWIN PUMP (ONLY)
22	Brown	Pump 2		Fuse terminal (Grey)	TWIN PUMP (ONLY)

Spare Parts

The drawings on the following pages show the internal components for a range of pressurisation equipment. Due to continuing development and minor design changes, some components may be changed without notice. Therefore, the drawings may not accurately reflect the current production design. If in any doubt about the compatibility of replacement parts, please contact

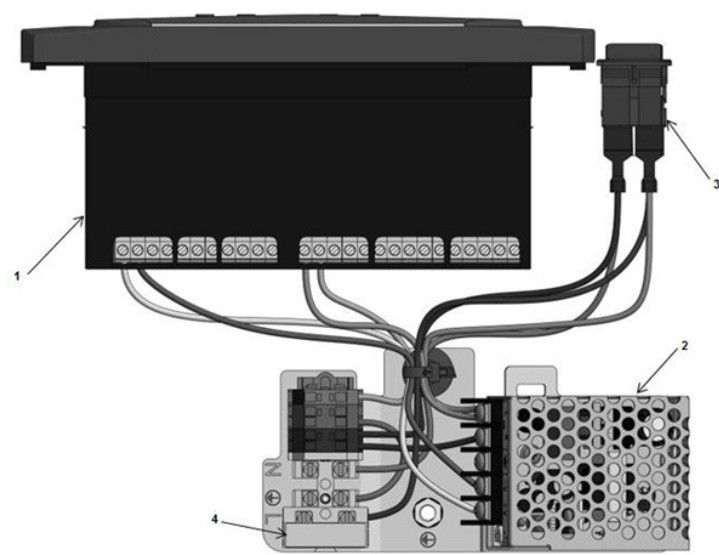

ID	Part Description
1	CONTROLLER
2	ELECTRICAL PLATE
3	TWO PUMP ON/OFF SWITCH

*Image for indication only

ID Number (4) is included with part of Electrical plate as standard, this rated at 6.3 Amp.

ECO Models

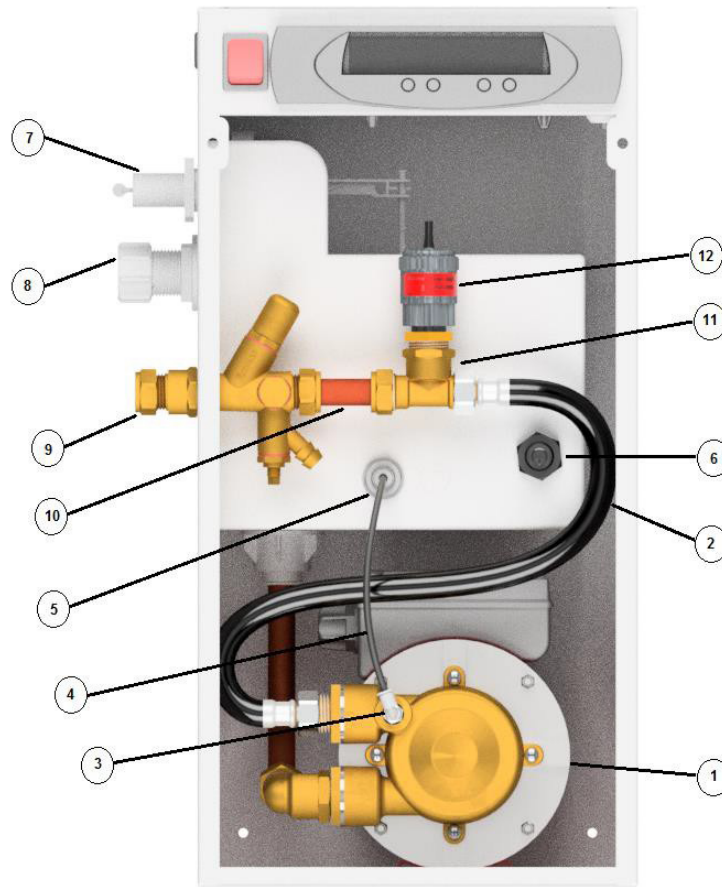

*Image for indication only

ID	Description
1	003 PUMP
2	FLEXIBLE HOSE
3	4 MM ELBOW
4	4 MM NYLON TUBE
5	4 MM BULKHEAD
6	Float Switch
7	FLOAT VALVE
8	OVERFLOW CONNECTION
9	COMBINED ISOLATION AND DRAIN
10	15 MM COPPER TUBE
11	15 X 15 X 1/2 TEE
12	TRANSDUCER

Troubleshooting

If for any reason the pressurisation unit does not seem to be functioning correctly, please refer to the table below for a list of solutions to known problems.

If the pressurisation unit is showing a fault code on the display, holding down the [SET] button will cause the current system pressure to be temporarily shown on the display.

Symptom	Problem	Solution
LOW PRESSURE fault is displayed and the pumps do not run	The internal isolation valve within the unit is closed	Open the internal isolation valve
	The system pressure has fallen below the LOW PRESSURE set point	Increase system pressure using a filling loop, or enable the SYSTEM FILL option
	The SPC CONTROLLER option is enabled	Disable the SPC CONTROLLER option
	The LOW PRESSURE set point is too high	Review the system specifications
HIGH PRESSURE fault is displayed	The isolation valve in the unit is closed	Open the internal isolation valve
	The system pressure has risen above the HIGH PRESSURE set point	Decrease system pressure using a suitable drain point
	The expansion vessel has failed or lost its pre-charge	Check the expansion vessel pre-charge and re-charge if necessary
	The expansion vessel is undersized	Review the expansion vessel selection
	The HIGH PRESSURE set point is too low	Review the system specifications
P1 and/or P2 FLOOD LIMIT is displayed	A large amount of water has been lost from the system	Investigate cause
	The pump is air-locked	Bleed the pump
	The unit is undersized for the system	Review unit selection
	The FLOOD LIMIT time is too short.	Consult Flowtech
P1 and/or P2 FAIL is displayed	The PUMP TYPE option is set incorrectly.	Review PUMP TYPE setting
	The relevant pump has failed	Replace pump
P2 FAIL is displayed but the unit is a single pump model	The PUMPS NUMBER option is incorrectly set to 2	Set PUMPS NUMBER to 1
LOW H2O fault is displayed	The mains water supply to the unit has been isolated	Turn on the mains water supply
	The mains pressure is poor	The fault will clear once the break tank has been re-filled
	A non-standard electrical connection has been made into terminals 19 & 20	Remove all non-standard electrical connections
	The low water float switch has failed	Replace low water float switch
	The digital controller has failed	Replace digital controller
HIGH H2O fault is displayed	A non-standard electrical connection has been made into terminals 21 & 22	Remove all non-standard electrical connections
	The digital controller has failed	Replace digital controller
Pressure reading does not match actual system pressure	The internal isolation valve within the unit is closed	Open the internal isolation valve
	The SENSOR TYPE option is set incorrectly	Review SENSOR TYPE setting
	A non-return valve has been installed between the unit and the system	Remove non-return valve
	The pressure sensor has failed	Replace pressure sensor
ERROR 1 fault is displayed	The SENSOR TYPE option is set incorrectly	Review SENSOR TYPE setting
	The pressure sensor has failed	Replace pressure sensor
Pump runs but does not make up pressure	The pump is air-locked and not pumping water	Bleed the pump

The pump is persistently becoming air-locked	The wrong/no flow restrictor is installed in the float valve (WMDA units only)	Check float valve flow restrictor selection (WMDA units only)
The break tank is overflowing and discharging water to drain or over the weir	The wrong/no flow restrictor is installed in the float valve	Check float valve flow restrictor selection
	The float valve position is set incorrectly	Set the float valve to its lowest position
	The float valve has failed	Replace float valve
	A pump non-return valve has failed	Replace non-return valve
The pump is repeatedly running in short bursts	The internal isolation valve within the unit is partially closed	Fully open the internal isolation valve
	The restriction in the connecting pipe work is too great	Increase bore/ reduce number of bends/ reduce length of connecting pipe work
	A pump non-return valve has failed	Replace non-return valve
	The expansion vessel has failed or lost its pre-charge	Check the expansion vessel pre-charge and re-charge if necessary
	The point of connection of the unit is too far away from the expansion vessel	Move unit/expansion vessel connection points closer together.
The buttons on the digital controller do not respond	The plastic housing of the digital controller has come apart and the PCB has moved	Reassemble the digital controller housing and ensure that the PCB is properly seated
The digital controller parameters are being corrupted	The controller is being subject to power spikes	Fit a suitable power filter
The digital controller does not power up when the unit is switched on	The fuse has blown	Replace the fuse
	The mains power supply is at an incorrect voltage or frequency	Check mains power supply
	The 12V transformer has failed	Replace Transformer
	The digital controller has failed	Replace digital controller
SERVICE is displayed on the screen	The unit is due an annual service	Contact service engineer

Warranty Details

This equipment is covered against manufacturing defects for 12 months from date of purchase from Flowtech Water Solutions Limited. This warranty covers the replacement of parts or products, verified as having a manufacturing defect, when inspected at the factory. Flowtech Water Solutions Limited reserves the right to inspect an installation to verify that the equipment has been installed in accordance with the written instructions.

Any modifications to the supplied equipment must be approved in writing by Flowtech Water Solutions Limited, failure to do so will invalidate the warranty.

Warranty - What Is Not Covered?

If a defect or problem has arisen as a direct result of the connected system, misuse, incorrect handling, incorrect installation or incorrect commissioning then any service visit is chargeable.

If a defect is identified as a manufacturing defect it will be addressed as described above, additional remedial works as a result of misuse, incorrect handling, incorrect installation or incorrect commissioning then the additional work is chargeable.

Installation costs and/or consequential losses are not covered by this agreement.

Site Visit

Before requesting a site visit, the following information must be made available to the Flowtech Water Solutions Limited sales team.

- Serial number of the equipment. Failure to verify the serial number at the time of visit will invalidate the warranty
- A purchase order to cover the work in the event that no manufacturing defect is found. (This must be the direct customer of Flowtech Water Solutions Limited).
- A site contact name and number
- A full description of the alleged fault
-

Commissioning

Please adhere to the following procedure and complete the individual commissioning leaflet and return to the following address:

Flowtech Water Solutions,
Unit 1 Lock Flight Buildings, Wheatlea Road
Wheatlea Industrial Estate
Wigan
Greater Manchester
WN3 6XP

If our own engineer is to commission the unit please have the leaflet on site for completion by the engineer.

Liability

Flowtech Water Solutions Limited can only respond to warranty queries from its direct customer. If in doubt, please contact your installer to establish the supply chain.

Contact Details

Telephone number - 0333 200 1756

Email - info@flowtech.org.uk

Service Record

It is recommended that your hot water system is serviced regularly and that the appropriate Service Record is completed. Before completing the appropriate Service Record below, please ensure you have carried out the service in the manufacturer's instruction

Service 1 Date_____ Engineer's Name _____ Company Name_____ Tel No_____ Comments_____ Signature _____	Service 2 Date_____ Engineer's Name _____ Company Name_____ Tel No_____ Comments_____ Signature _____
Service 3 Date_____ Engineer's Name _____ Company Name_____ Tel No_____ Comments_____ Signature _____	Service 4 Date_____ Engineer's Name _____ Company Name_____ Tel No_____ Comments_____ Signature _____
Service 5 Date_____ Engineer's Name _____ Company Name_____ Tel No_____ Comments_____ Signature _____	Service 6 Date_____ Engineer's Name _____ Company Name_____ Tel No_____ Comments_____ Signature _____
Service 7 Date__ Engineer's Name _____ Company Name_____ Tel No_____ Comments_____ Signature _____	Service 8 Date__ Engineer's Name _____ Company Name_____ Tel No_____ Comments_____ Signature _____

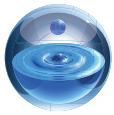

flowtech[®]
WATER SOLUTIONS

flowzone[®]

MEMBERS AREA

This section of the **flowtech**[®] website holds information exclusively for members. Members will need to log in to gain access to these pages.

Our member's will be granted exclusive access to our technical resource library. Within this resource is a wide range of product information including data sheets, technical drawings, O&M Manuals and training videos



flowcare[®]

AFTER SALES SERVICE

At **flowtech**[®] we operate a network of Service Engineers located throughout the UK who are supported by our offices located in and Greater Manchester. The distribution of engineers means that in the majority of cases we are less than 4 hours away from attending a customer call out.

We place great emphasis on providing technical back up to support our Service Engineers in resolving some difficult operational and technical issues. We pride ourselves on completing a project on time, within budget and never leaving a problem unresolved, or a customer waiting. This quality of service has made us the first choice for our customers.

FOR FURTHER INFORMATION OR ASSISTANCE

contact us

Flowtech Water Solutions are experts in water services and water booster sets. We have continuously supplied a wide range of standard and custom products since being founded in 1996.

MANUFACTURE & SUPPLY

TELEPHONE : 0333 200 1756

EMAIL: info@flowtech.org.uk

SERVICE & MAINTENANCE

TELEPHONE : 0333 200 1813

EMAIL: service@flowtech.org.uk

WEBSITE: www.flowtech.org.uk

ADDRESS : Unit 1 Lock Flight Buildings, Wheatlea Industrial Estate,
Wigan, Greater Manchester WN3 6XP United Kingdom



Membership No. 700106

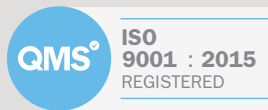

Certificate No. 185352020